

Selecting a Quick Change Toolpost

One of the best additions you can make to your conventional metal turning lathe is to install a quick change toolpost. These tool posts usually consist of a base block holder and also several interchangeable toolholders that mount to the base. The benefits of a quick change toolpost is that your turning tools can be set in their own holder allowing them to be adjusted on centre height and ready for use next time the tool is selected. These interchangeable holders have a self-locking height adjustment that enables you to have them pre-set so you can quickly swap out your tools easily and affectively.

SELECTION THE QUICK CHANGE TOOLPOST

Prior to selecting the quick change toolpost, certain information about your lathe is require. *refer 1. & 2.*

1. The centre height of the lathe.

This is the measurement taken from the bed to the centre line of the lathe, or half of what the lathe can swing over the bed. (Fig.1) This will help in selecting the correct quick change toolpost for your lathe

2. The amount of height adjustment available (H dimension Fig.3)

This is the measurement taken from the top of the compound slide with original toolpost removed to the lathe centerline (H dimension Fig.2). This is the most important dimension for selecting the proper toolpost. To insure that there will be enough height adjustment so that the tools can be set on the centre line the (H dimension Fig.2) must be within the MIN-MAX range of the tool post (H dimension in Fig.3).

Fig.1

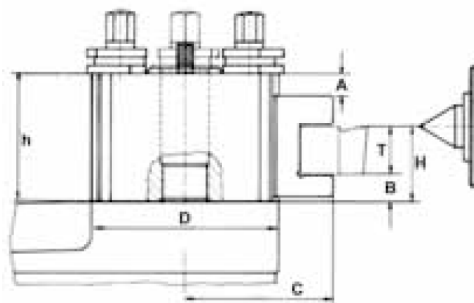
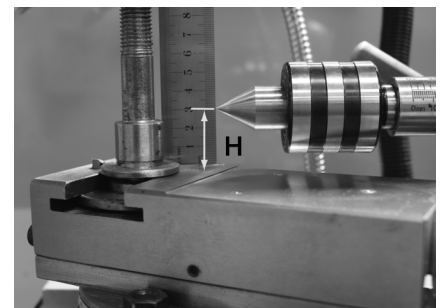

Fig.2



Example

This lathe has a 160mm centre height **Fig.1** Therefore we can select either the QA-140 or QA-150. Now check "H" dimension **Fig.2** This lathe measures 30mm in height, so both the QA-140 and QA-150 can be used as the 30mm dimension is between 28-41mm allowing for up and down adjustment

Fig.3

MODEL	CENTRE HEIGHT	A	B	C	H	h	T	D	No. of Sides	No. of Holders	Wt.(kg)	CODE
QA-100	75-115	14	6	50	16-30	40	12	58	2	5	2.5	L280
QA-140	150-170	15	20	60	28-41	60	16	74	2	4	6.2	L292
QA-150	150-170	15	20	60	28-41	60	16	74	2	4	6.2	L295
'V' Holder												
"A"	168	10	12	75	32-42	60	20	100	3	6	9.8	L293
"BR-BP"	202	15	13	90	38-53	75	25	115	3	5	14.1	L294
"B"	230	18	15	100	47-65	85	32	125	3	5	23.0	L296
"C"	280	21	19	108	51-72	94	32	145	3	5	28.0	L297
"D"	350	34	21	137	61-95	120	40	175	3	5	50.0	L298

PLEASE NOTE! Some modifications maybe required to make the quick change toolpost fit to your lathe. The toolpost stud on your lathe may need to be machined or a bush may need to be made so the toolpost locates correctly onto the existing toolpost stud.